

1092 Series LED Panel Mount Indicators Wire Leads

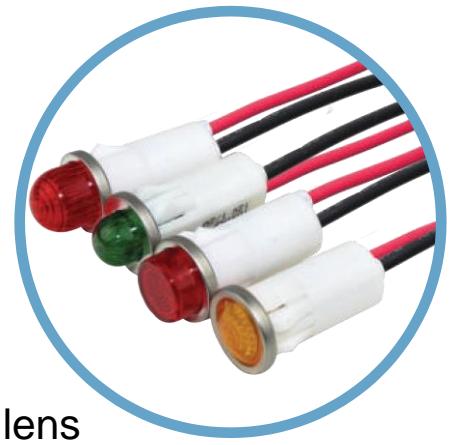

Available in four different lens styles, three diffused lens colors and operating voltage range of 12V, 28V and 125V
Snap fit into 0.500" (12.7mm) panel hole diameter



Applications

- Industrial
- Transportation
- Food Service
- People Movers
- Medical
- Maritime
- Oil and Gas Industry
- Manufacturing
- Automation & Control

Key Features

- Snaps fit into 0.500" (12.7mm) panel hole
- LED illumination
- Four different lens styles available: Hi Hat, Hi Dome, Semi Dome and Small Dome
- Front-panel mount
- Front panel snap-in mounting requires no additional hardware
- Life expectancy of 100,000 hours
 - High brightness LEDs for daylight viewing
- UL/cUL Listed. File Number E20356
- Order speed nuts separately to provide maximum fastening power with minimal installation torque.
- Order gasket separately to provide water, oil, air and dusttight.
- 4.4"/4.8" wire leads
- 0.187" (4.75mm) tab terminal version also available
- Available in wide operating voltage of 12V, 28V and 125V
- Three colors available: Red, Green, Amber
- Transparent and clear lenses provide visibility during the daylight
- Solution to retrofit: save energy and reduce the costs
- 'D' mounting hole aids anti-rotation
- Compliant with RoHS and REACH requirements
- For customized options, please contact us

Ordering Data

The 1092 Series is available in a range of standard features and options. To specify your Panel Mount Indicator, simply choose one option from each column. An example is shown below

| Series | Lens Style | Color | Voltage | |
|------------|------------|-------|---------|--------------------------|
| 1092 | | | - | |
| Hi-Dome | A | | 12V | 12V |
| Hi-Hat | C | | 28V | 28V |
| Semi-Dome | D | | 125VAC | 125VAC |
| Small-Dome | M | | | |
| | | | | luminous intensity (Typ) |
| | | Red | 1 | 13,000 mcd |
| | | Amber | 3 | 13,000 mcd |
| | | Green | 5 | 12,000 mcd |

Example: 1092A5-12V
1092 with Hi-Dome lens - Green LED and 12 Volts



Accessories Ordering Data [order separately]

Speed Nut: SN0461-C



O'Ring Gasket: SPC472



Product Dimensions

Hi Dome

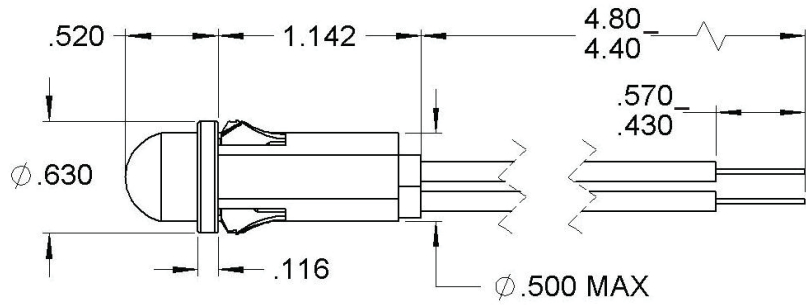
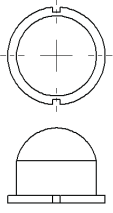

Hi Hat

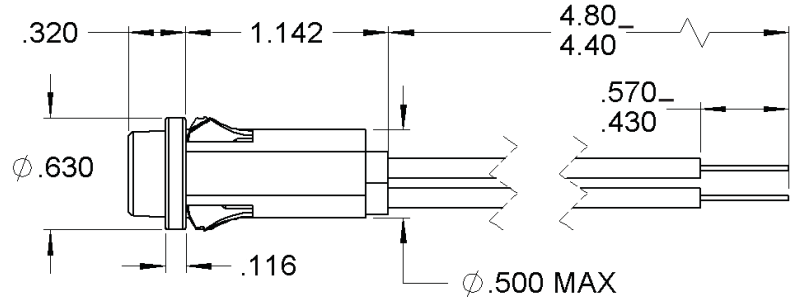
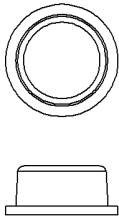

Semi Dome

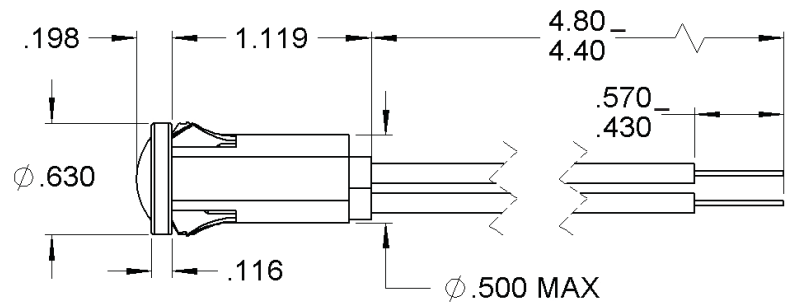
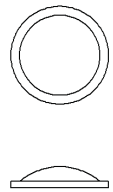

Small Dome

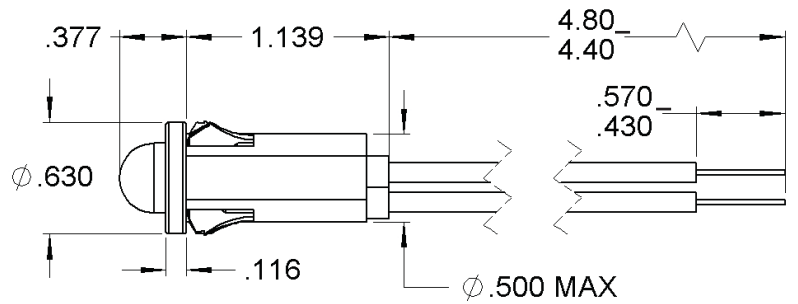
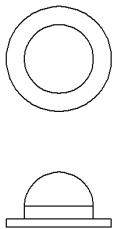

Mounting Hole (All)

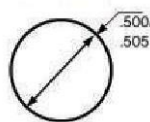

Standard Mounting Hole

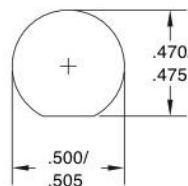

D-Mounting Hole

Dimensions in inches

Product Specifications

| Materials | |
|------------|---|
| Housing | White Nylon UL94 V-2 |
| Lens | Transparent Polycarbonate UL94 V-2 |
| Bezel | Polished stainless steel |
| Wire Leads | Tinned Copper Conductor PVC Insulation |

| Voltage Table | | |
|---------------|------------|----------|
| Nominal | VAC | VDC |
| 12V | 10 to 14 | 10 to 14 |
| 28V | 26 to 30 | 26 to 30 |
| 125V | 105 to 125 | — |

| Installation Specifications | |
|-----------------------------|--|
| Mounting Hole | 0.500" to 0.505" (12.70 to 12.83 mm) |
| D-Mounting Hole | 0.470" to 0.475" (11.94 to 12.07 mm) |
| Panel Thickness | 0.020" to 0.100" (0.51 to 2.54 mm) |
| Wire Leads | 18 AWG -105°C - 600V lead color: red and black, 4.40"/4.80" (111.8/121.9 mm) long, stripped .430"/.570" (10.9/14.5 mm) Anode(+): Red lead |

| Internal Resistor | |
|------------------------|--------------------------|
| 12V | 390Ω |
| 28V | 1200Ω |
| 125V | 15000Ω + rectifier diode |
| Forward Current Rating | 25mA |

Tem
Opera
Tempe
Stora
Tempe

Accessory options [order separately]

O-Ring Gasket

Part Number **SPC472**

The 1092 Gasket is designed to seal many types of media, including water, air, dust, and oil. The panel gasket is intended to provide a seal between the panel and the 1092 Panel Mount Indicator.

Meets ASTM D2000 standard.

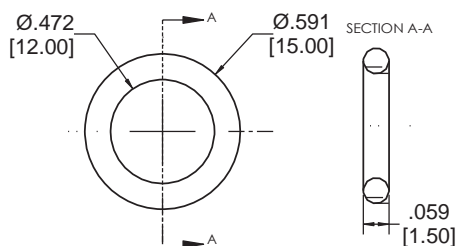

Dimensions in inches [mm]

| Material | |
|------------------------------|-----------------|
| Buna-N, Durometer A50, black | |
| Installation Specification | |
| Internal Diameter | 0.472" (12 mm) |
| Thickness | 0.059" (1.5 mm) |
| Operational Temperature | -30°F to +225°F |

Push-on speed nut

Part Number **SN0461-C**

Description: Speed nut with coating, which secures the indicator in place

- One piece, self-locking, heat-treated, spring-steel fastener that replaces threaded nut, lock washer or spanner washer
- Eliminates time-consuming assembly operations.
- Fast and easy to apply, the speed nut fastener provides maximum holding power at minimum cost per fastener
- It does not shake loose from vibration, yet can be easily loosened without worry about rust-frozen screw threads.
- For smaller components where space is premium
- Requires less torque than standard hex-nuts
- Can be installed prior to painting process so threads won't fill.

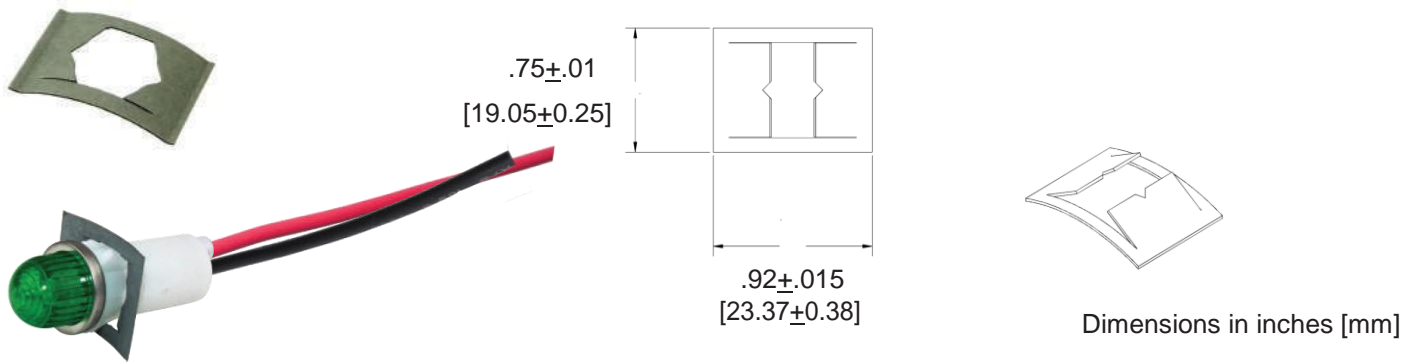

| Material | |
|-----------------------|--------------|
| Speed Nut (one piece) | Spring Steel |

| Installation Specification | |
|----------------------------|-------------------|
| Stud Size | 0.485" (12.319mm) |

Compliances and Approvals

